

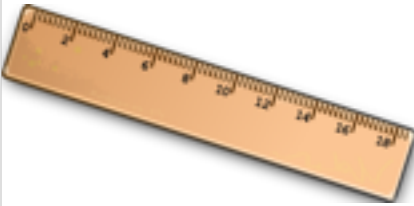







You will hear the recording of a radio ad two times. For each price you hear, write it under the correct item. For example, "Tenemos grapadoras por quince pesos." You will write "15" under the stapler.

\*Not all items are in the ad

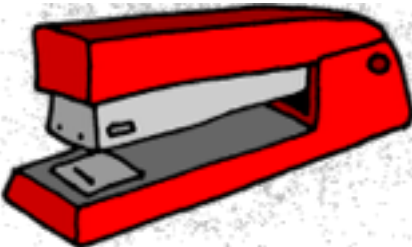
		
\$ _____	\$ _____	\$ _____

		
\$ _____	\$ _____	\$ _____

15

		
\$ _____	\$ _____	\$ _____